

VENTURKA 

D-FWA
Wall Mounted
Axial Fan

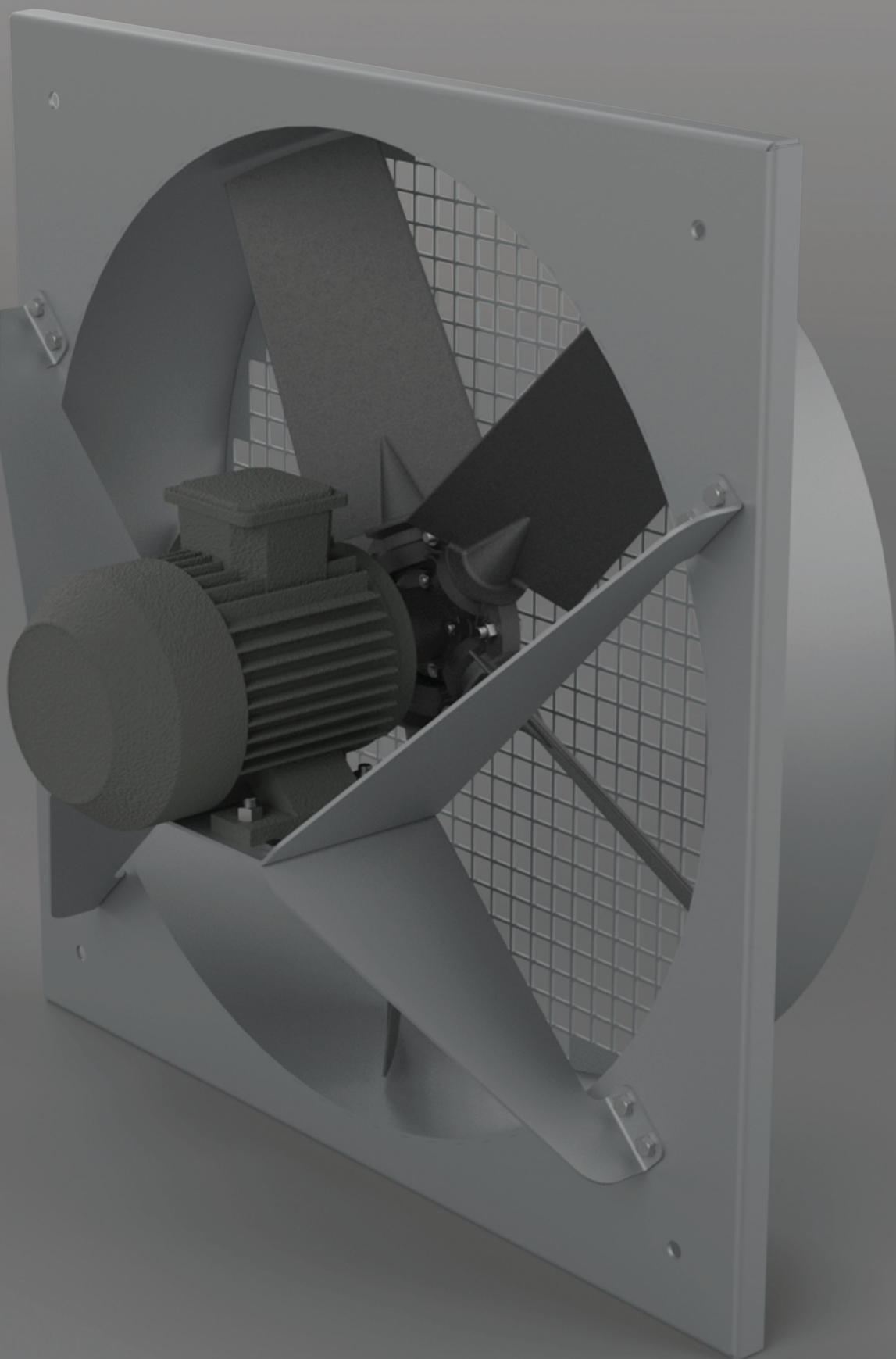

venturka.com

Technical Specifications

WALL MOUNTED AXIAL FAN

D-FWA series wall mounted axial fans are the ideal fans for wall mounting in ventilation systems where high air flow is required. Thanks to their compact construction, they can be mounted directly on the wall. D-FWA series wall mounted axial fans have high performance, trouble-free operation.

It is manufactured between Ø500mm and Ø1000mm diameters. The body is made of high quality, corrosion-resistant galvanized steel. The propellers are made of special aluminum alloy with adjustable blade angles. According to the project, uni-directional or reversible options are available. It is manufactured as standard (380 V - 50 Hz) or other voltages and frequencies. Motors can be single-speed or double speed and have Class H, S1, IP55 insulation.

Optionally, it can be manufactured with Ex-Proof feature.

Usage Areas

It can be used in all kinds of industrial, office, warehouse, hangar, workshop and residential projects to meet the ventilation requirement.

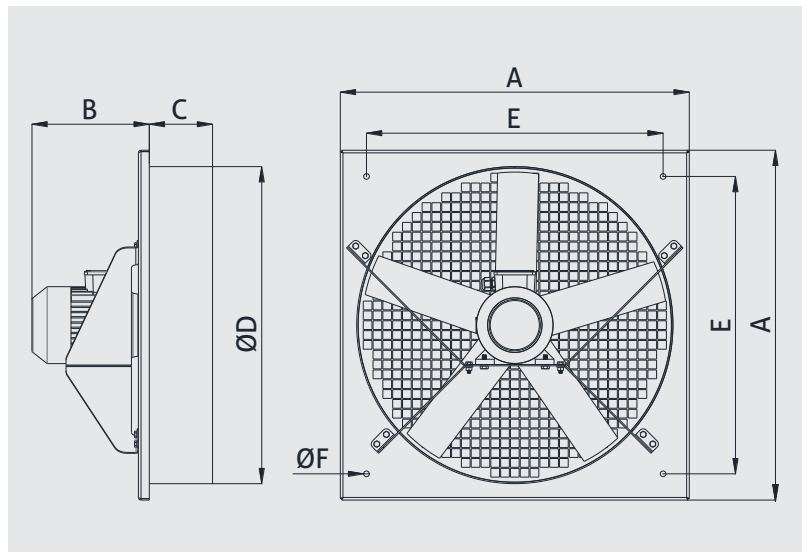
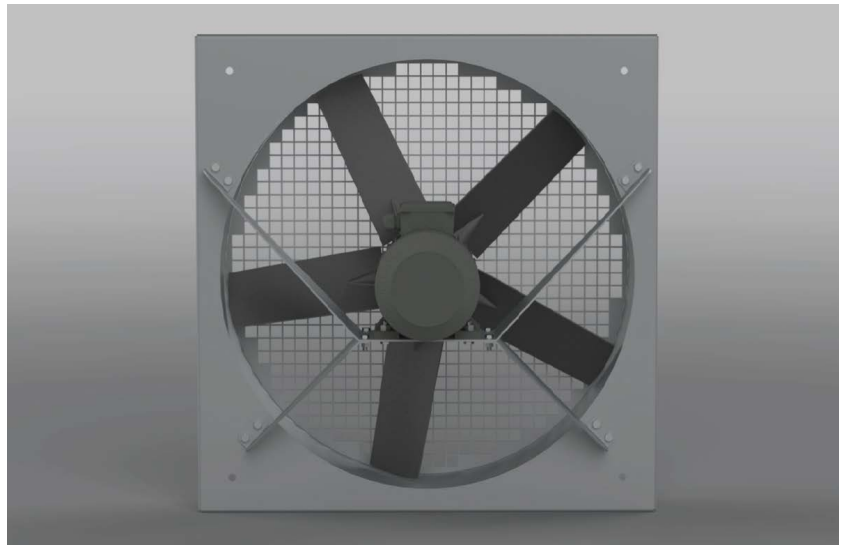

| MODEL | A | B | C | D | E | E | MOTOR POWER | CURRENT | NOS. OF POLES | VOLTAGE | FREQUENCY |
|------------|------|-----|-----|------|------|----|-------------|---------|---------------|---------|-----------|
| | mm | mm | mm | mm | mm | mm | kW | A | | V | Hz |
| D-FWA 400 | 500 | 210 | 105 | 420 | 380 | 13 | 0,18 | 0,6 | 4 | 380 | 50 |
| D-FWA 450 | 550 | 210 | 105 | 470 | 430 | 13 | 0,37 | 1,1 | 4 | 380 | 50 |
| D-FWA 500 | 600 | 260 | 105 | 520 | 480 | 13 | 0,55 | 1,6 | 4 | 380 | 50 |
| D-FWA 600 | 700 | 260 | 105 | 620 | 580 | 13 | 0,75 | 2,1 | 4 | 380 | 50 |
| D-FWA 700 | 800 | 270 | 145 | 725 | 680 | 13 | 1,1 | 2,6 | 4 | 380 | 50 |
| D-FWA 800 | 950 | 320 | 195 | 825 | 830 | 13 | 2,2 | 5,1 | 4 | 380 | 50 |
| D-FWA 900 | 1050 | 340 | 220 | 925 | 930 | 15 | 4 | 8,2 | 4 | 380 | 50 |
| D-FWA 1000 | 1150 | 36 | 220 | 1025 | 1030 | 15 | 5,5 | 11,3 | 4 | 380 | 50 |

D-FWA 400

Nos. of Blades 5
Hub Size 5
Pitch Angle 30°
Nos. of Poles 4
Material Aluminum

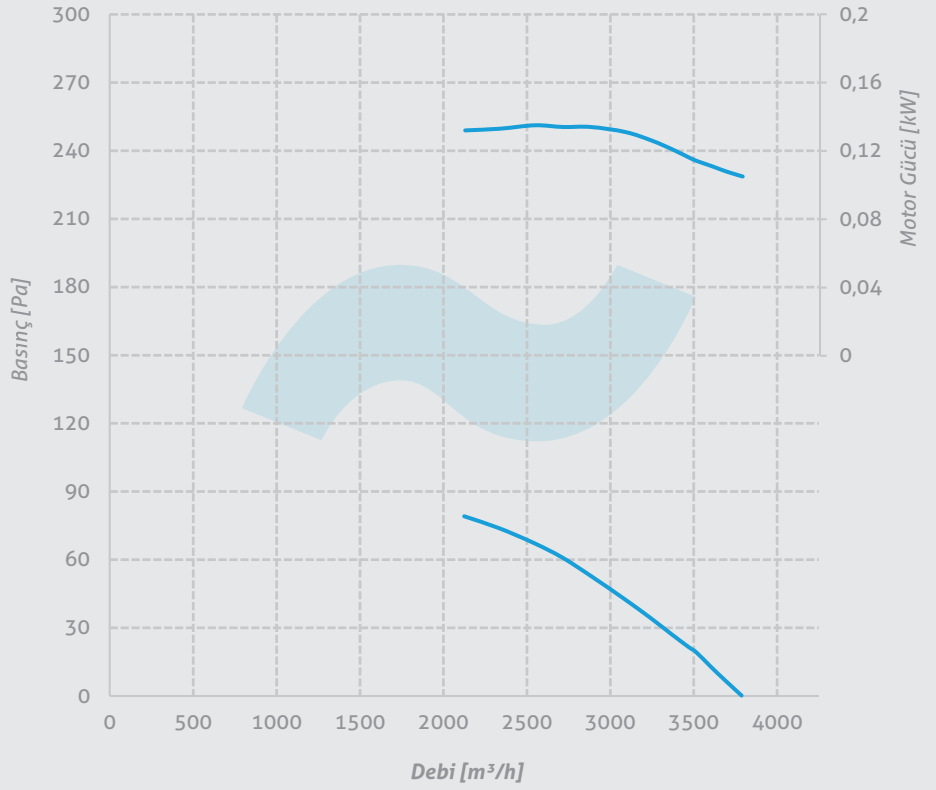

D-FWA 450

Nos. of Blades 5
Hub Size 5
Pitch Angle 35°
Nos. of Poles 4
Material Aluminum

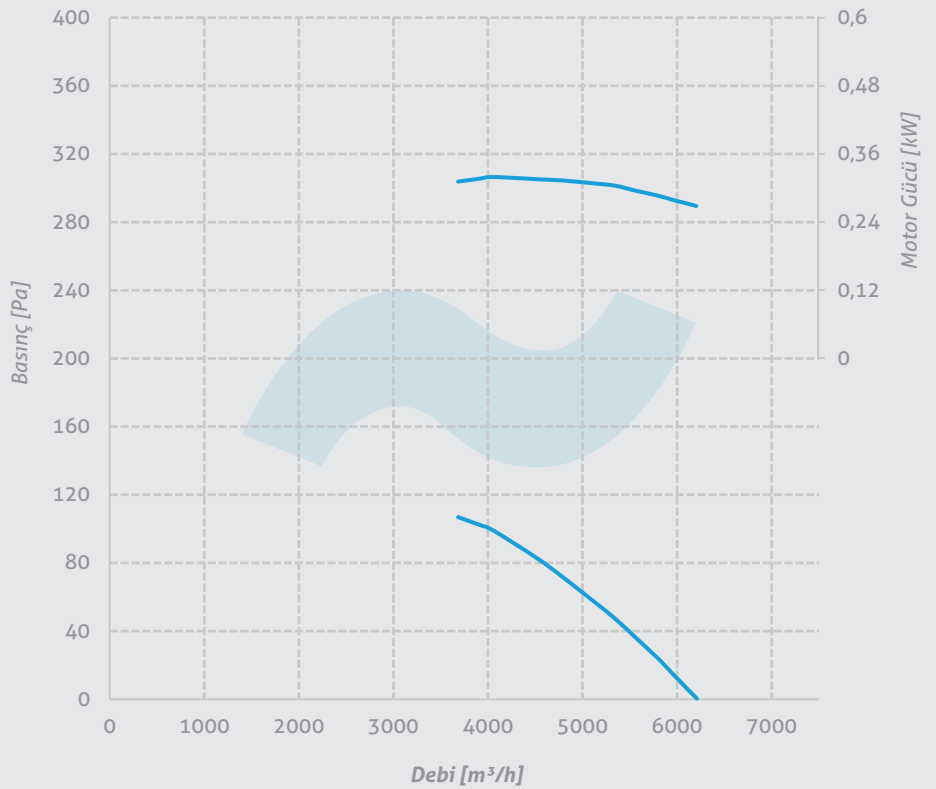

Performance Curves

D-FWA 500

Nos. of Blades 5
Hub Size 5
Pitch Angle 35°
Nos. of Poles 4
Material Aluminum

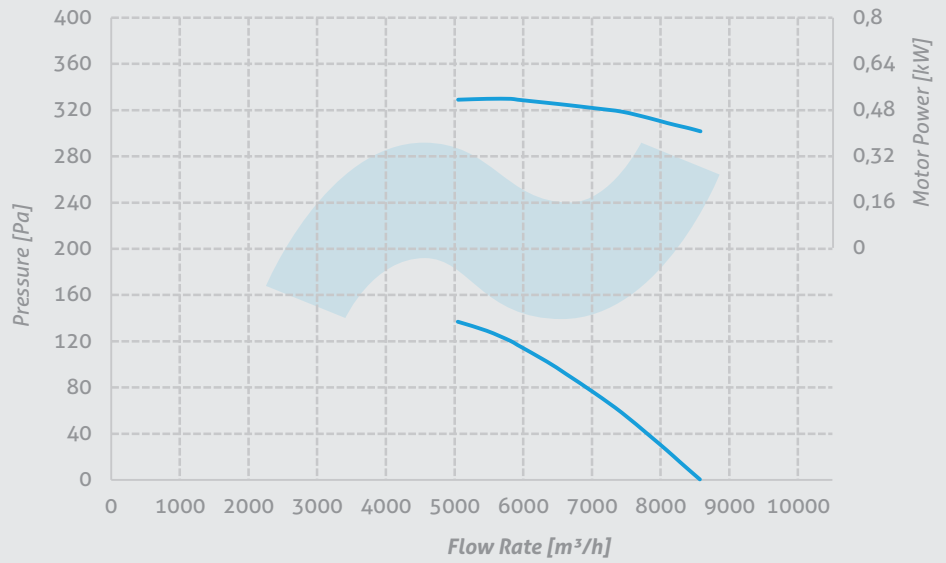

D-FWA 600

Nos. of Blades 5
Hub Size 5
Pitch Angle 30°
Nos. of Poles 4
Material Aluminum

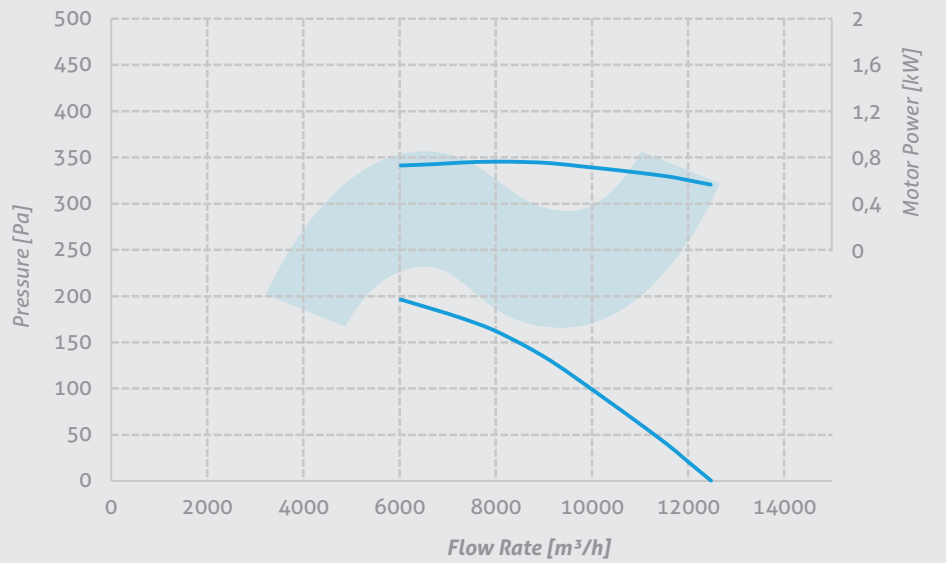

D-FWA 700

Nos. of Blades 5
Hub Size 5
Pitch Angle 25°
Nos. of Poles 4
Material Aluminum

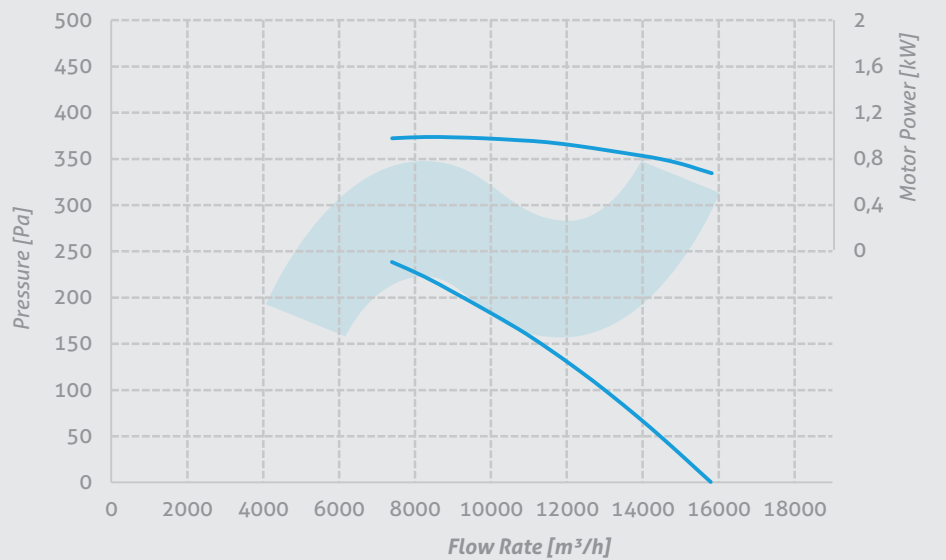

Performance Curves

D-FWA 800

Nos. of Blades 5
Hub Size 5
Pitch Angle 30°
Nos. of Poles 4
Material Aluminum

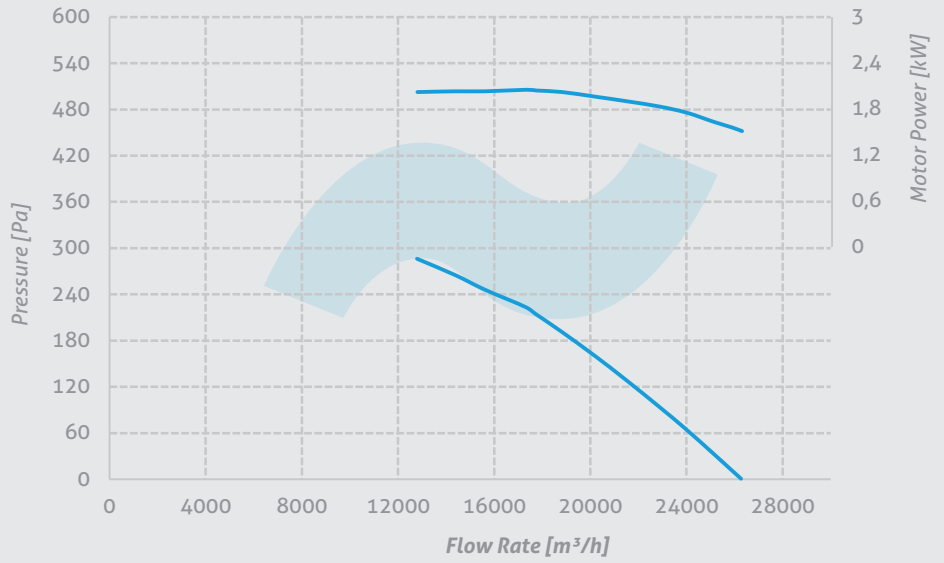

D-FWA 900

Nos. of Blades 5
Hub Size 5
Pitch Angle 35°
Nos. of Poles 4
Material Aluminum

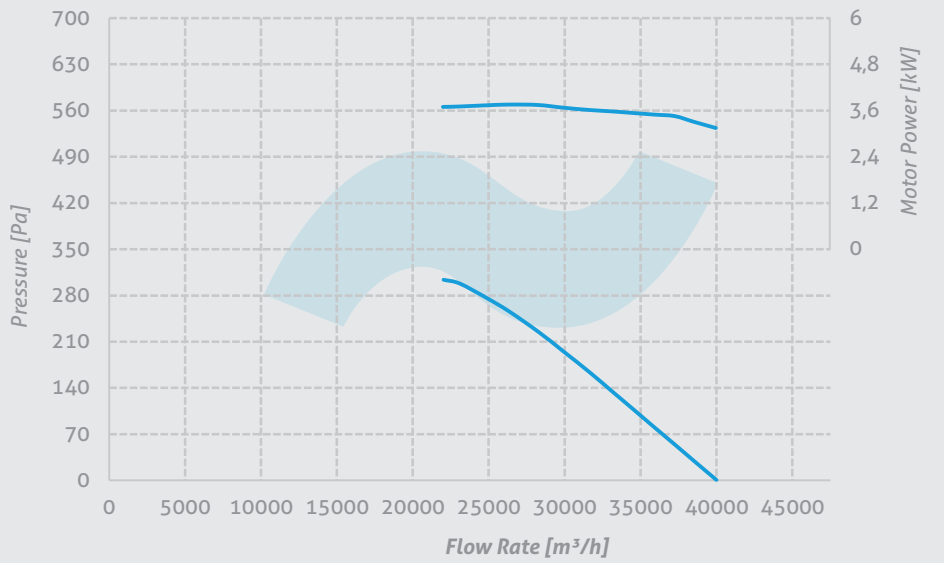

D-FWA 1000

Nos. of Blades 5
Hub Size 5
Pitch Angle 37,5°
Nos. of Poles 4
Material Aluminum

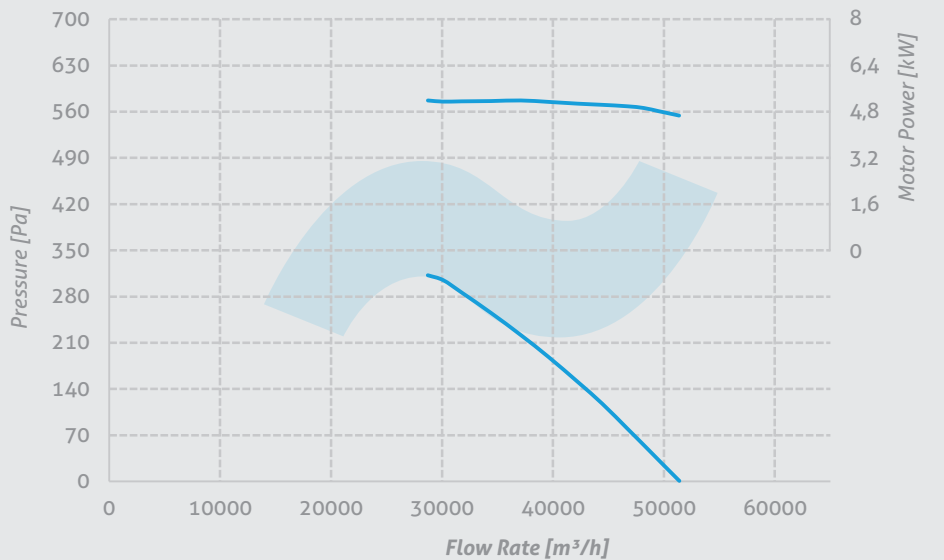

VENTURKA

Contact:

Export Sales Representative: Mr. Alparslan ASLAN

Mobile: **+90 538 341 93 11** (WhatsApp: OK)

E-Mail: **export@venturka.com**